

A Division of Systems, Inc.

POWERAMP

Premium Loading Dock Systems

CM-Series

Dock Leveler

Owner's Manual

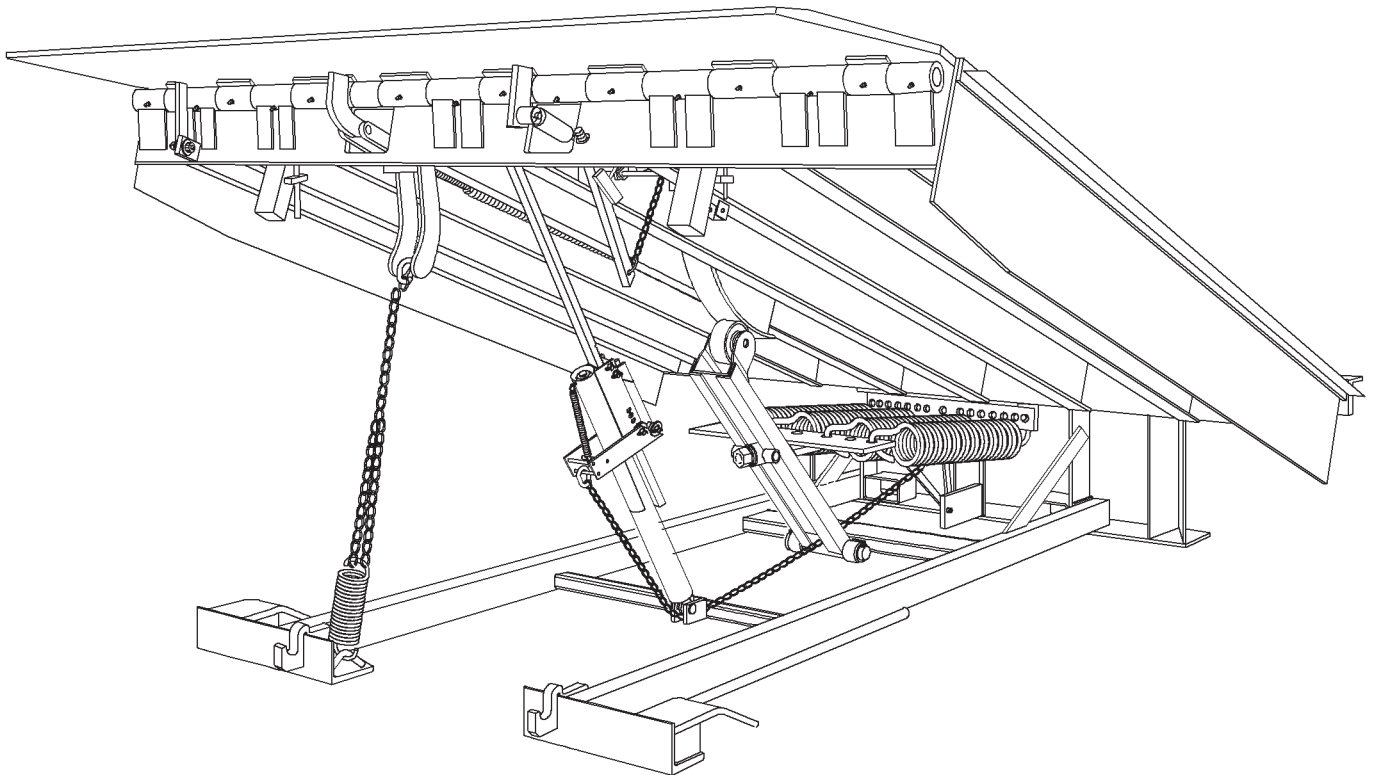

POWERAMP • Division of Systems, Inc. • W194 N11481 McCormick Drive • Germantown, WI 53022
800.643.5424 • fax: 262.257.7349 • www.docksystemsinc.com • techservices@docksystemsinc.com

Table of Contents

	Page
Safety	
Recognize Safety Information	1
General Operational Safety Precautions	1
Operational Safety Precautions	2
Maintenance Safety Precautions	4
Safety Decals	5
Introduction	
General Information	7
Dock Leveler Stock Specifications	7
Component Identification	8
Installation	
Prepare Pit	9
Prepare Dock Leveler	10
Install Dock Leveler	12
Operation	
Theory	17
Operating Instructions	18
Ramp Loading/Unloading Instructions	19
End Loading/Unloading Instructions	20
Maintenance	
Service Dock Leveler Safely	21
Periodic Maintenance	22
Adjustments	
Adjust Lift Arm Spring and Lip Assist Spring Tension	24
Adjust Lip Stop Bolt	26
Troubleshooting	
Troubleshooting	27
Parts	
Hold-Down Mechanism	29
Frame Components	30
Platform Components	32
Toe Guard/Weather Seal—Optional	35
Miscellaneous	
Customer Information	37
Warranty	Back Cover

Recognize Safety Information

Safety-Alert Symbol



The Safety-Alert Symbol identifies important safety messages on equipment, safety signs, in manuals, or elsewhere. When you see this symbol, be alert to the possibility of personal injury or death. Follow the instructions in the safety message.

DANGER

The use of the word DANGER signifies the presence of an extreme hazard or unsafe practice which will most likely result in severe injury or death.

WARNING

The use of the word WARNING signifies the presence of a serious hazard or unsafe practice which may result in serious injury or death.

CAUTION

The use of the word CAUTION signifies possible hazard or unsafe practice which could result in personal injury.

IMPORTANT

The use of the word IMPORTANT is to draw attention to a procedure that needs to be followed to prevent machine damage.

General Operational Safety Precautions



Read and understand the operating instructions and become thoroughly familiar with the equipment and its controls before operating the dock leveler.

Never operate a dock leveler while a safety device or guard is removed or disconnected.

Never remove DANGER, WARNING, or CAUTION signs or decals on the equipment unless replacing them.

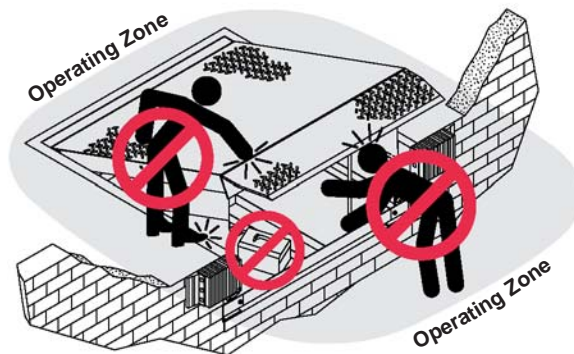

DO NOT activate the equipment until all unauthorized personnel in the area have been warned and have moved outside the operating zone.

Remove any tools or foreign objects from the operating zone before starting.

Keep the operating zone free of obstacles that could cause a person to trip or fall.

SAFETY

Operational Safety Precautions



Learn the safe way to operate this equipment. Read and understand the manufacturer's instructions. If you have any questions, ask your supervisor.

DANGER



Stay clear of dock leveling device when freight carrier is entering or leaving area.



Do not move or use the dock leveling device if anyone is under or in front of it.



Keep hands and feet clear of pinch points. Avoid putting any part of your body near moving parts.

WARNING



Chock/restrain all freight carriers. Never remove the wheel chocks until loading or unloading is finished and truck driver has been given permission to drive away.



Do not use a broken or damaged dock leveling device. Make sure proper service and maintenance procedures have been performed before using.

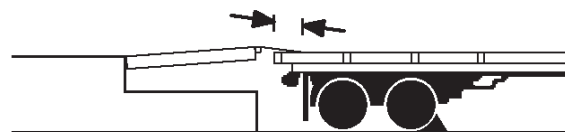

Make sure lip overlaps onto trailer at least 4 in. (102 mm).

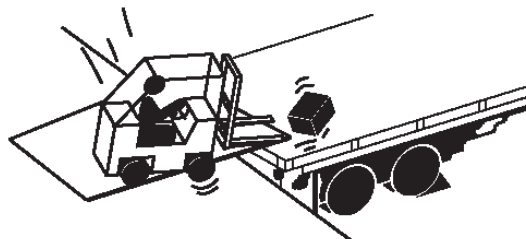

Keep a safe distance from both side edges.

⚠ WARNING

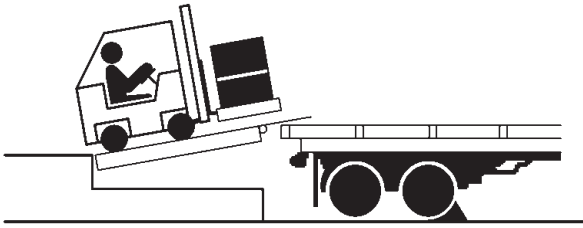

Do not use dock leveling device if freight carrier is too high or too low.



Do not overload the dock leveling device.

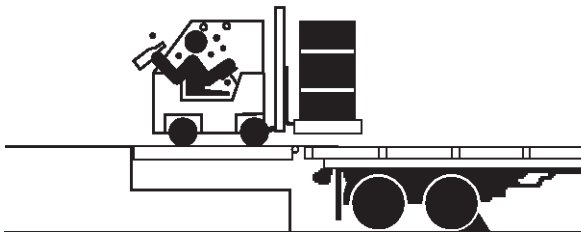

Do not operate any equipment while under the influence of alcohol or drugs.

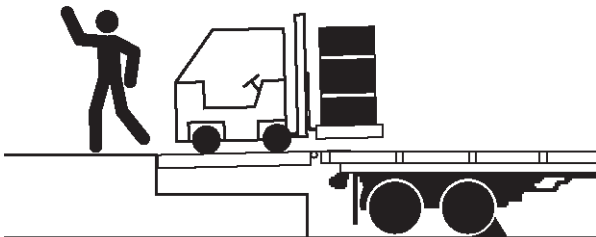

Do not leave equipment or material unattended on dock leveling device.

SAFETY

Maintenance Safety Precautions

WARNING



Always post safety warnings and barricade the work area at dock level and ground level to prevent unauthorized use of the unit before maintenance is complete.

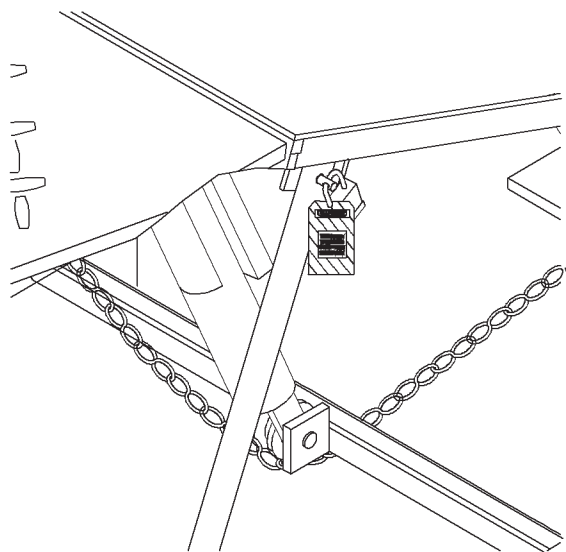

The platform maintenance prop must be in the service (upright) position when working under the dock leveler. For maximum protection, use an OSHA approved locking device to lock the maintenance prop in the service position. Only the person servicing the equipment should have the key to unlock the device.

WARNING

DO NOT grind or weld if hydraulic fluid or other flammable liquid is present on the surface to be ground or welded

DO NOT grind or weld if uncontained hydraulic fluid or other flammable liquid is present. Stray sparks can ignite spills or leaks near the work area. Always clean up the oil leaks and spills before proceeding with grinding or welding.

Always keep a fire extinguisher of the proper type nearby when grinding or welding.

Failure to follow these instructions may result in serious personal injury or death.

WARNING

ALWAYS stand clear of dock leveler lip when working in front of the dock leveler. Failure to do this may result in serious personal injury or death.

Safety Decals

WARNING: Danger
Contains compressed spring.
Do not attempt to open or adjust.
Not User Serviceable.

Safety Decal on Hold-Down Mechanism

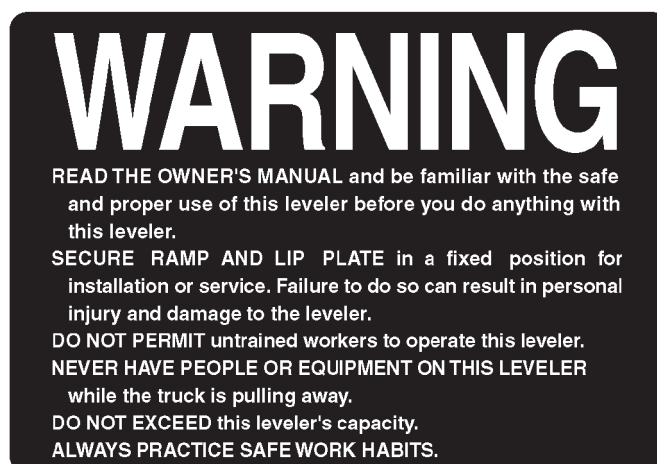

Safety Decal on Leveler Frame

This page intentionally left blank

General Information

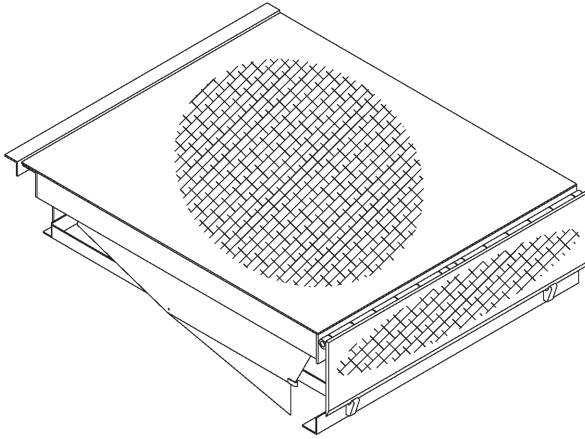

Congratulations on your choice of a Poweramp dock leveler. This manual covers the CM-series mechanical dock leveler.

Designed by Poweramp to be a marvel of simplicity and efficiency, your dock leveler, when properly installed, will provide many years of trouble-free performance with an absolute minimum of maintenance. To obtain maximum performance and longest possible use, a simple program of preventive maintenance is recommended.

Once again, thank you and congratulations on your purchase of a Poweramp mechanical dock leveler.

Dock Leveler Stock Specifications

CM-Series dock levelers are available in the following sizes, weight capacities, and options:

Width

- 6 ft (1828.8 mm)
- 6-1/2 ft (1981.2 mm)
- 7 ft (2133.6 mm)

Length

- 5 ft (1424 mm)
- 6 ft (1828.8 mm)
- 8 ft (2438 mm)
- 10 ft (3048 mm)

Capacity (CIR*)

- 20,000 lb (9072 kg)
- 25,000 lb (11 340 kg)
- 30,000 lb (13 608 kg)

*CIR (Comparative Industry Rating)

Call Poweramp for your specific needs.

INTRODUCTION

Component Identification

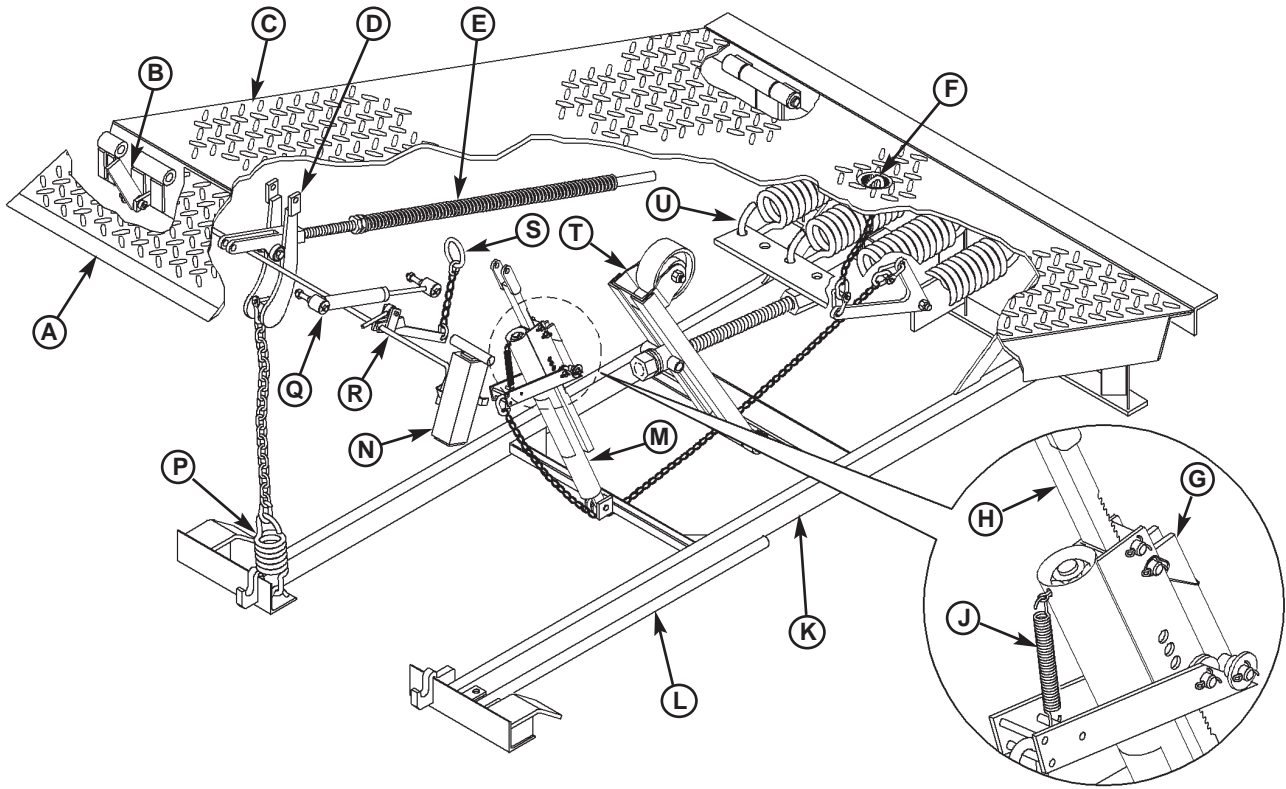

- | | | | |
|------------------------|-------------------------|-----------------------------|---------------------------|
| A—Lip | F—Platform Release Ring | L—Platform Maintenance Prop | R—Safety Leg Linkage |
| B—Lip Maintenance Prop | G—Ratchet Pawl | M—Hold-Down Mechanism | S—Safety Leg Release Ring |
| C—Platform | H—Ratchet Bar | N—Safety Leg (2 used) | T—Lift Arm Assembly |
| D—Lip Link | J—Pawl Spring | P—Lip (Snubber) Spring | U—Lift (Main) Spring |
| E—Lip Assist Spring | K—Main Frame | Q—Lip Shock Absorber | Assembly |

Prepare Pit

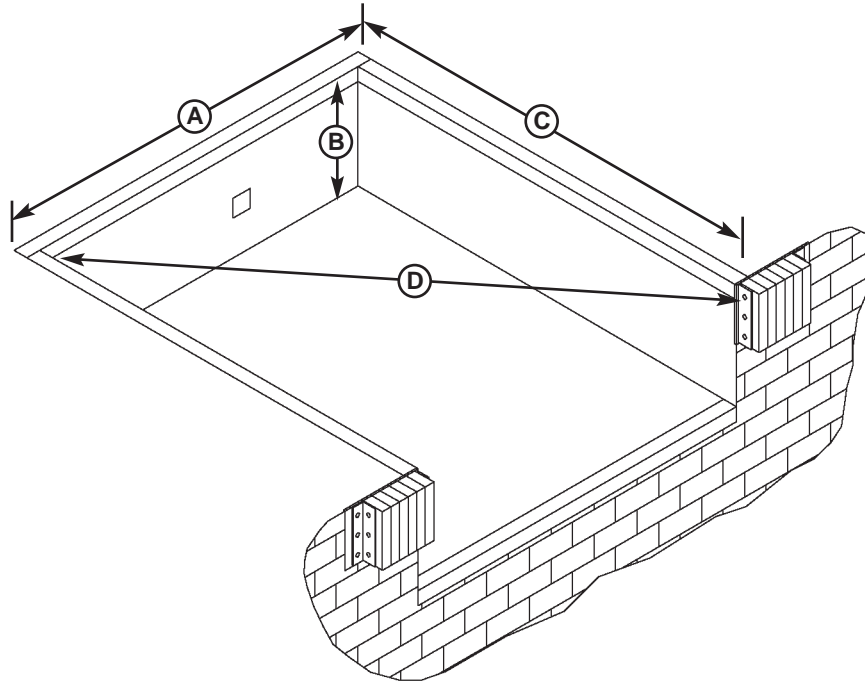

A—Distance (Pit Width)
(Front and Rear)

B—Distance (Dock Floor-to-Pit
Floor) (All Four Corners)

C—Distance (Pit Length)
(Both Sides of Pit)

D—Distance (Pit Corner-to-Corner)
(Top, Bottom, and Both Sides)



WARNING

Post safety warnings and barricade the work area at dock level and ground level to prevent unauthorized use of the dock leveler before installation has been completed.

Failure to follow the installation instructions can result in damage to dock leveler, the facilities, and/or serious personal injury or death.



CAUTION

Only trained installation professionals with the proper equipment should install this product.

IMPORTANT

DO NOT remove the shipping bands around the dock leveler lip until instructed to do so.

Before lowering the dock leveler into the pit, the following must be performed:

1. Remove all debris from the pit and sweep the pit clean.
2. Check the entire dock leveler pit for proper construction according to approved/certified pit drawings. Make sure pit is square by making the following measurements:
 - Measure pit width distance (A) at both front and rear of pit.
 - Measure dock floor-to-pit floor distance (B) at all four corners.
 - Measure pit length distance (C) at both sides.
 - Measure corner-to-corner (criss-cross) distance (D) at both sides. Take measurements at dock floor level and at pit floor level.

If any measurement is off by more than 1/8 in. (3.18 mm), contact Poweramp Technical Services before proceeding.

INSTALLATION

Prepare Dock Leveler

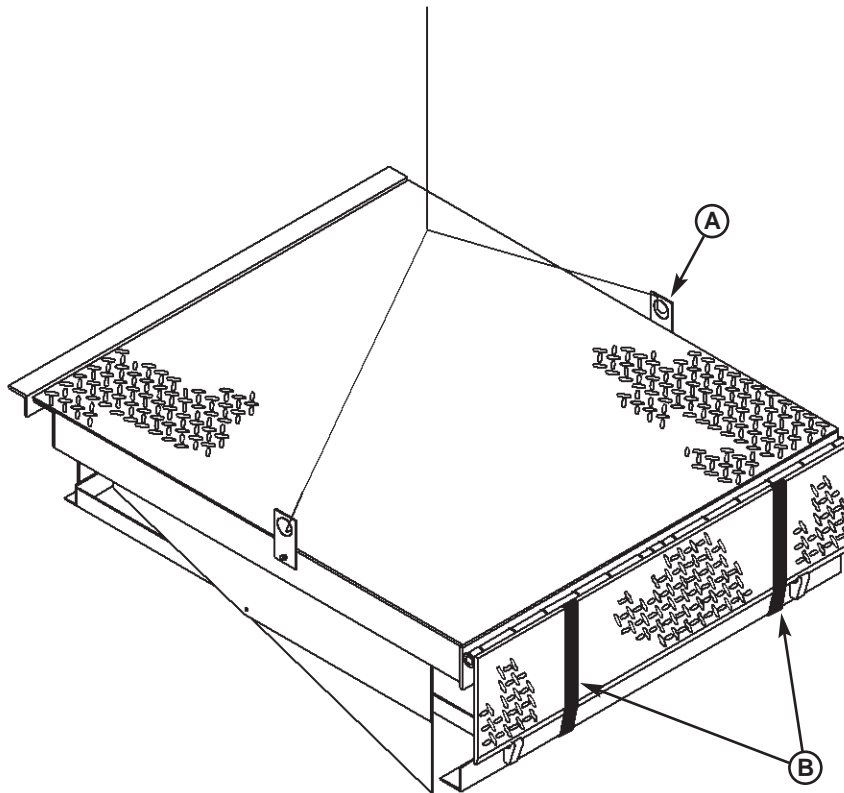

A—Lifting Bracket (2 used)

B—Shipping Bands



WARNING

The dock leveler is heavy. Use a lifting device and chains with the appropriate lifting capacity and reach.

Always use the lifting brackets provided with the unit whenever lowering or lifting a dock leveler into or out of a pit.

Failure to follow these instructions may result in damage to the dock leveler and/or serious personal injury or death.

Poweramp dock levelers are designed with installation in mind. Each unit is shipped with lifting brackets (A) fastened to the platform side joists.

IMPORTANT

DO NOT remove the shipping bands (B) around the platform lip and leveler frame at this time. The shipping bands are needed to hold the leveler together during the installation process.

1. Remove any bumpers that may be banded, or bolted to the frame of the dock leveler.

DO NOT remove the shipping bands (B) around the platform lip and leveler frame at this time.

IMPORTANT

DO NOT over-tighten the lifting bracket hardware. Over-tightening can damage the weather seal, if equipped.

NOTE: Overall width of platform and lifting brackets (A) must be kept to a minimum to prevent interference between the lifting brackets and the pit walls as the dock leveler is lowered into the pit.

2. Make sure the mounting hardware of lifting brackets (A) is snug. The brackets should pivot relatively freely on the mounting cap screw. DO NOT over-tighten.
3. Attach lifting chains to lifting brackets (A) and to a lifting device (i.e., hoist or fork truck) having the appropriate lifting capacity and reach.
4. Remove wood blocks that are attached to the leveler frame before putting the dock leveler into the pit.

INSTALLATION

Install Dock Leveler

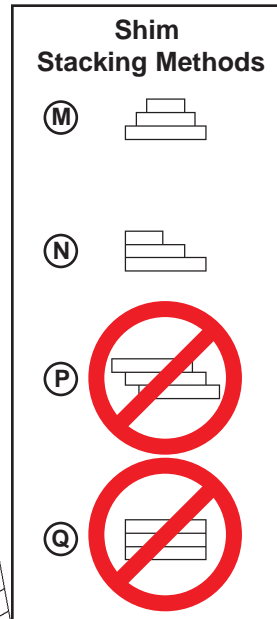
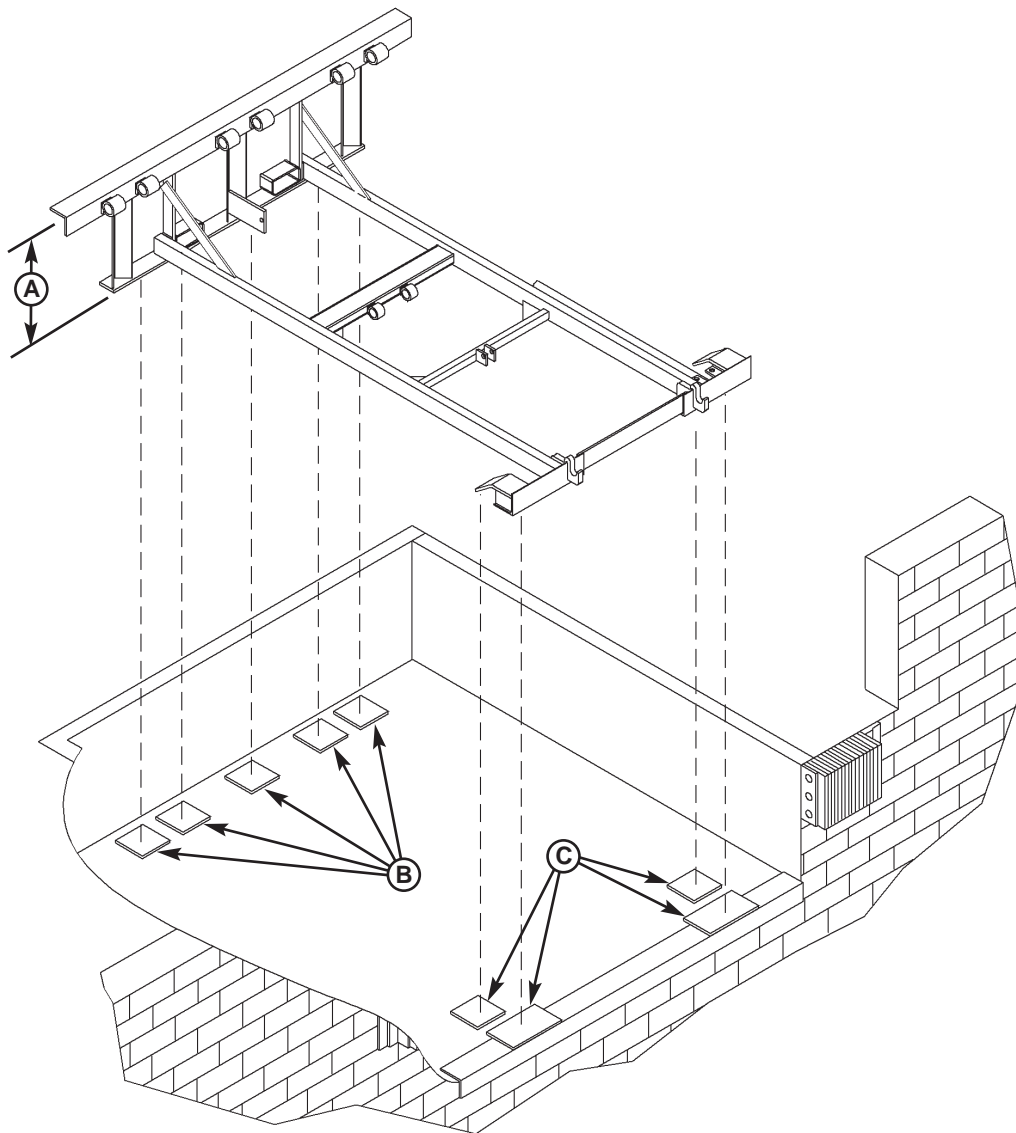

- A—Distance (Leveler Frame Height)
- B—Shim Locations (Under Rear Vertical Supports)
- C—Shim Locations (Under Lip Keepers and Prop)
- D—Dock Floor
- E—Rear Pit Curb Angle
- F—String
- G—Rear Hinge Frame Angle
- H—Distance (Dock Floor-to-Pit Floor)
- J—Distance (Top of Shim Stack-to-Dock Floor)
- K—Shim Stack
- L—Dock Leveler Frame
- M—Pyramid (Preferred)
- N—Stepped (Acceptable)
- P—Offset (Not Acceptable)
- Q—Straight (Not Acceptable)

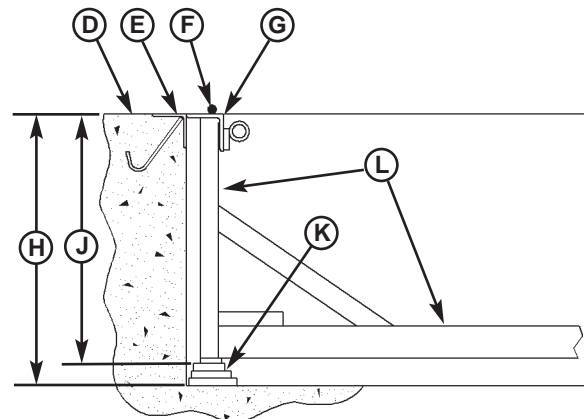

NOTE: Poweramp dock levelers are designed with a nominal 1/2 in. (12.7 mm) shimming distance to allow for pit inconsistencies.

1. Determine height of shim stack (K) for each shim location (B) by performing the following:
 - a. Measure leveler frame height distance (A).
 - b. Measure dock floor-to-pit floor distance (H) at each shim location (B). Write down the dimensions obtained at each location.
 - c. Subtract distance (A) from distance (H) to obtain the shim height. Repeat for each shim location.

IMPORTANT

The minimum size of the shim that contacts the leveler frame (i.e., the top shim of each shim stack) must be at least 4-1/2 x 4-1/2 in. (114.3 x 114.3 mm) to support the full width of the frame rail and to provide a shelf for a fillet weld.

Use the thickest shim stock possible for stability and weld penetration purposes. DO NOT use multiple layers of 1/8 in. (3.18 mm) or thinner shim stock.

2. Using the results obtained in step 1, create the individual shim stacks on the pit floor at locations (B). Build each shim stack (K) using the pyramid method (M) (preferred) or stepped method (N) with the top shim having a minimum size of 4-1/2 x 4-1/2 in. (114.3 x 114.3 mm) and each successive lower shim being larger so the shims can be welded together using a fillet weld. DO NOT use offset method (P) or straight method (Q).

NOTE: To assist in obtaining an accurate measurement of distance (J), use a string (F) pulled tight across the pit opening, directly over the shim locations.

3. Verify that each shim stack is at the correct height by measuring distance (J) [top of shim stack (K) to dock floor]. Distance (J) must equal the dock leveler height (A).

4. Put a 1/4 in. (6.6 mm) thick shim at locations (C) (under lip keepers/maintenance prop and safety legs). Make sure shims are larger than frame angle iron so pyramid or stepped stacking method can be used.

NOTE: A 1/4 in. (6.6 mm) thick shim at locations (C) is used only as a starting point. The final shim stack height will be determined after the dock leveler is lowered into the pit.



WARNING

The dock leveler is heavy. Use chains and a lifting device with the appropriate lifting capacity and reach. Failure to do so may result in damage to dock leveler and/or serious personal injury or death.

5. Using an appropriate lifting device connected to the lifting brackets, lower dock leveler into the pit so rear hinge frame angle (G) is tight against rear pit curb angle (E) across full width of the leveler frame.
6. Allow rear of dock leveler to rest on the rear shims while keeping the front of the dock leveler level with the dock floor.
7. Add shims at front shim locations (C) so front of dock leveler will stay level with dock floor when leveler is resting fully on shims.

INSTALLATION

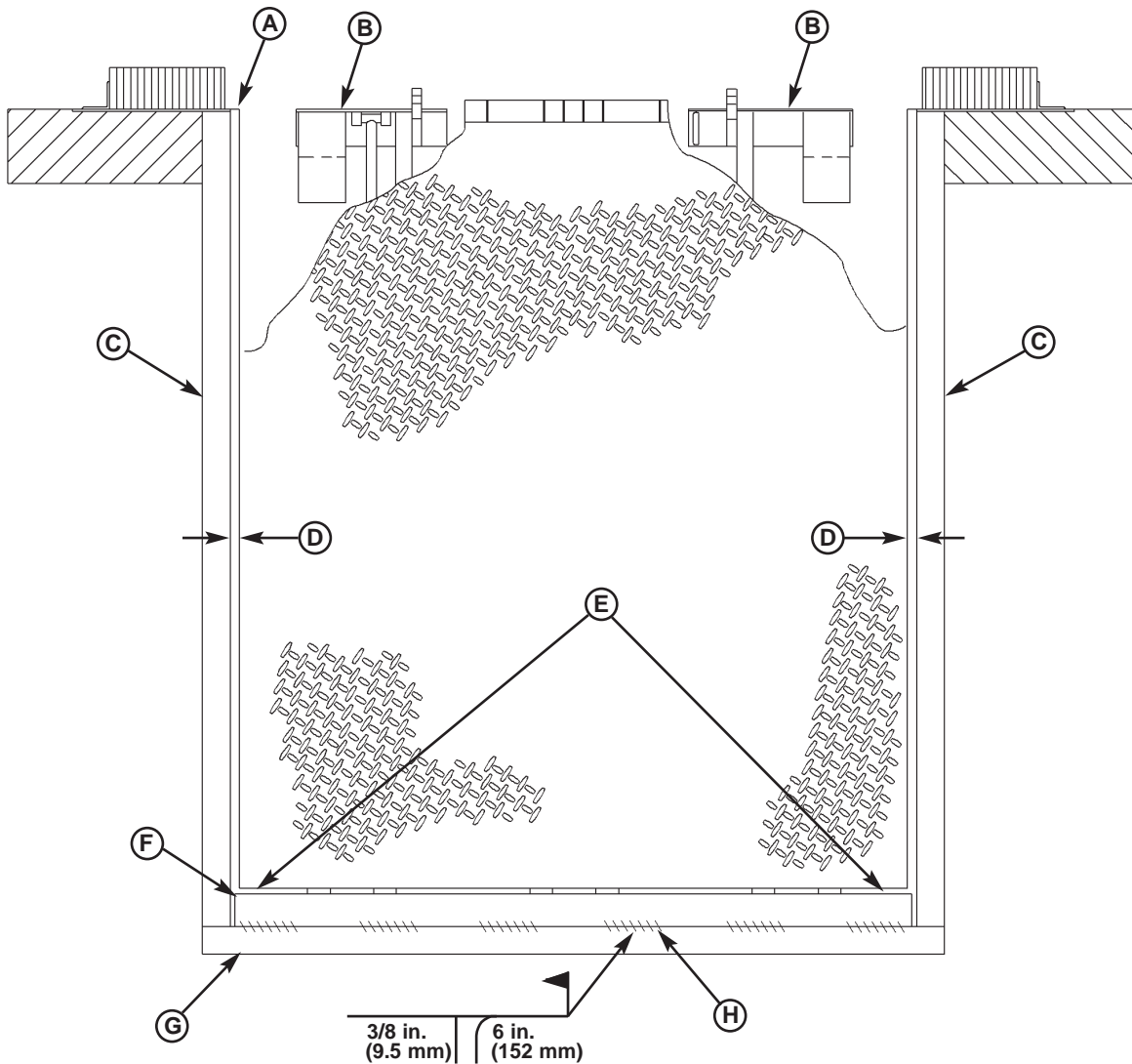

- | | | | |
|----------------------|---------------------------------|--------------------------|--|
| A—Front of Dock Pit | C—Side Pit Curb Angle | E—Pry Locations | G—Rear Pit Curb Angle |
| B—Dock Leveler Frame | D—Gap [3/4 in. (19 mm) Minimum] | F—Rear Hinge Frame Angle | H—Flare Bevel Weld, Typical (To Fit Spacing) |

8. With rear hinge frame angle (F) tight against rear pit curb angle (G), perform/check the following:
 - Pry between the platform and rear hinge frame angle at locations (E) to make sure rear edge of platform is parallel to the rear hinge frame angle (F).
 - Gap (D) must exist equally along both sides of leveler so weather seal (if equipped) will not bind during dock leveler operation.
9. If gap (D) cannot be obtained equally at both sides of leveler, grind or add material at the rear edge of rear hinge frame angle (F) as needed.
10. Allow the dock leveler to rest fully on the shim stacks. Make sure the leveler is in the cross-traffic (stored) position with lip resting on lip keepers.
11. Check that a smooth and level transition exists between the dock floor and the dock leveler platform. Add or remove shims as necessary until a smooth transition is obtained.
12. If leveler cannot be squared and made level as instructed in steps 8–10, contact Poweramp Technical Services.

WARNING

DO NOT grind or weld if hydraulic fluid or other flammable liquid is present on the surface to be ground or welded.

DO NOT grind or weld if uncontained hydraulic fluid or other flammable liquid is present. Stray sparks can ignite spills or leaks near the work area. Always clean up the oil leaks and spills before proceeding with grinding or welding.

Always keep a fire extinguisher of the proper type nearby when grinding or welding.

Failure to follow these instructions may result in serious personal injury or death.

IMPORTANT

Always ground welding equipment to the dock leveler frame, NEVER to the platform.

DO NOT weld continuously along the full length of the rear hinge frame angle. This can put unnecessary stress on the leveler components, causing the leveler not to function correctly and shortening the lifespan of the affected components.

NOTE: The illustration on the previous page shows a typical weld pattern. The weld pattern will vary slightly depending on size of dock leveler.

13. With the rear hinge frame angle (F) tight against the rear pit curb angle (G), weld the rear hinge frame angle (F) to the rear pit curb angle (G) using a 3/8 in. (9.5 mm) flare bevel skip weld —each weld being 6 in. (152 mm) long.

Start at each end with a 6 in. (152 mm) long weld. Space all the other welds out evenly leaving approximately 6 in. (152 mm) space between each weld.

Alternate welding locations to distribute heat. Welding sequentially from one end to the other may cause warping or distortion.

14. Weld front of dock leveler frame (B) to shims located under the keepers, then weld the shims to the front pit curb steel.

WARNING

Make sure all personnel are outside of the leveler operating zone and stand clear of the platform lip before removing the shipping bands. Failure to do this may result in serious personal injury or death.

15. With the leveler welded in place remove the shipping bands from around the lip and frame.
16. Disconnect lifting device and chains from the lifting brackets.

WARNING

Make sure all personnel are outside of the leveler operating zone and clear of the platform lip before activating the leveler. Failure to do this may result in serious personal injury or death.

IMPORTANT

When activating the leveler, always pull AND hold the platform release ring until the platform is at the full-raised position. Releasing the ring while the platform is still rising may result in damage to the equipment.

17. Pull and hold the release ring (located in recess at rear of platform) until the platform is fully raised. Check for binding as platform rises.
18. Slowly walk out onto the platform to lower the platform. Allow the platform to lower to the cross-traffic position. Check for binding as platform lowers.
19. If binding occurs, reposition leveler and/or add or remove shims as necessary. Raise and lower platform again. If platform still binds, contact Poweramp Technical Services for further instructions.
20. Check that the leveler is flush with the dock floor and that the platform lip contacts both lip keepers evenly.

INSTALLATION

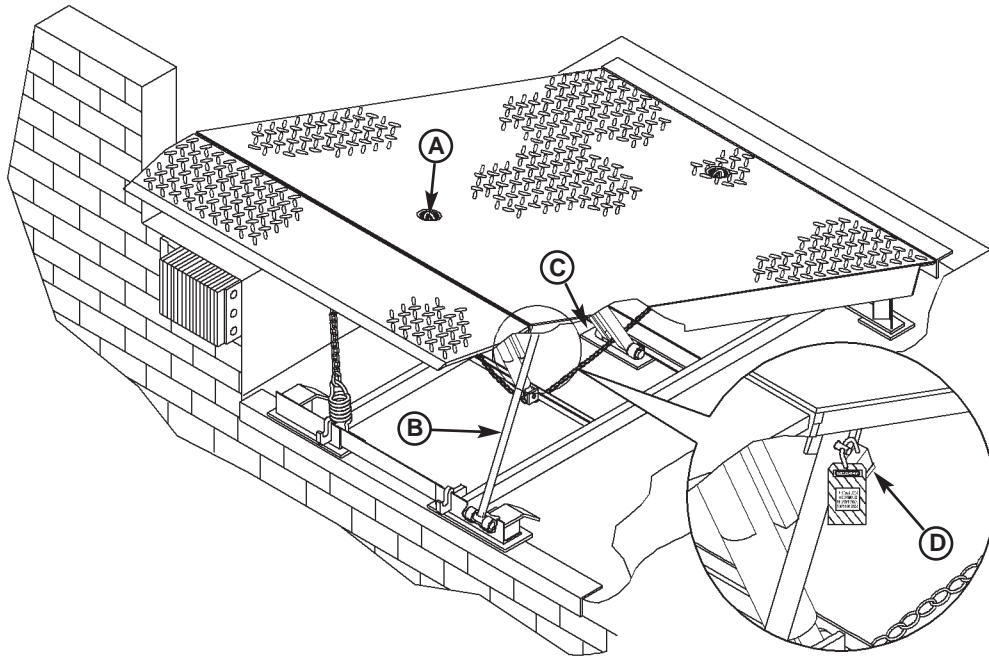

A—Safety Leg Chain Pull Ring B—Platform Maintenance Prop C—Shim Location (Under Lift Arm Pivot) D—Locking Device

21. Pull the release ring to raise platform. Engage the platform maintenance prop (B) in the service (upright) position and lock the maintenance prop at this position using an OSHA approved locking device (D). Engage lip maintenance prop.

WARNING

Make sure the platform is properly supported in the raised position before entering the pit to finish weld the shims. Failure to do this may result in serious personal injury or death.

22. Install shims under lift arm at locations (C) using the pyramid shimming method. The lift arm pivot must be solidly shimmed the entire length of the lift arm pivot. Make sure the lift arm pivot is level from side-to-side.

23. Finish weld all shims using a fillet weld.

- Weld all shims within each shim stack to each other, then weld the shim stack to the leveler frame.
- Weld the front leveler frame shim stacks to the front pit curb steel if not done previously.

24. When all welding has been completed, remove all slag then paint all the welds and shims.

25. Remove the lifting brackets from the platform side joists.

26. Disengage the platform maintenance prop.

27. Slowly walk out onto the platform to lower the platform until it is at the cross-traffic (stored) position.

28. Check operation of dock leveler by cycling the leveler at least four times.

- When the platform is at full height, lip will be fully extended.
- Lip will begin to drop after full height is reached, taking approximately 12 seconds to fully fold.

29. Check below-dock position by walking platform down before lip folds completely.

- Lip will be over lip keepers.
- Platform safety legs will be resting on frame.

30. Check full below-dock position by walking the platform down. Pull and hold safety leg chain (A) before lip folds completely.

31. If the lip does not extend fully or lip folds too quickly, see appropriate symptom in the Troubleshooting section.

32. Install the dock bumpers as required.

Theory

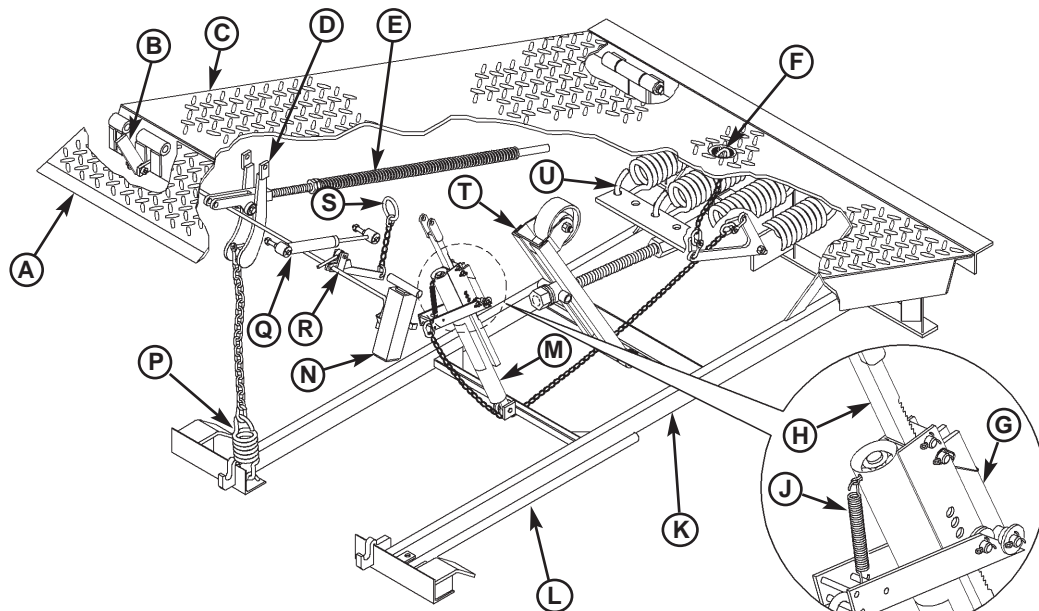

- | | | | |
|------------------------|-------------------------|-----------------------------|--------------------------------|
| A—Lip | F—Platform Release Ring | L—Platform Maintenance Prop | Q—Shock Absorber |
| B—Lip Maintenance Prop | G—Ratchet Pawl | M—Hold-Down Mechanism | R—Safety Leg Linkage |
| C—Platform | H—Ratchet Bar | N—Safety Leg (2 used) | S—Safety Leg Retract Pull Ring |
| D—Lip Link | J—Pawl Spring | P—Lip Spring | T—Lift Arm |
| E—Lip Assist Spring | K—Main Frame | | U—Lift Springs |

The CM-series mechanical dock leveler uses large lift springs (U) to apply force to lift arm (T). The lift arm pushes against the underside of the platform (C), rolling on the cam (not pictured) forcing the platform to rise. The force of the spring tension is just enough to lift the weight of the platform.

The ratchet pawl disengages only when the platform release ring (F) is pulled AND held. Spring tension from pawl spring (J) causes the ratchet pawl to engage the ratchet bar when the release ring is let go.

When the platform rises to approximately 2–3 inches (51–76 mm) from its full raised height, the lip spring (P) and a chain pulls the lip link (D) forward. This, in conjunction with the lip assist spring (E), causes the lip linkage to push the lip out and up. The lip assist spring also helps control the amount of time required for the lip to fully fold.

IMPORTANT

When activating the leveler, always pull AND hold the platform release ring until the platform is at the full raised position. Releasing the ring while the platform is still rising may result in damage to the equipment.

To actuate the dock leveler platform, the operator pulls and holds the platform release ring (F) located in the recess at the rear of the platform. This causes ratchet pawl (G) to disengage from ratchet bar (H). With the ratchet pawl disengaged, spring tension from lift springs (U) forces the platform to rise.

NOTE: Ratchet pawl (G) and bar (H) are part of the hold-down mechanism (M)

To lower the platform, the operator walks out onto the platform. The platform will lower until the extended lip rests on the truck bed. If the lip did not fully extend or there is no truck at the dock, the platform will lower until one of the following conditions occur:

- Lip is resting on lip keepers (cross-traffic position).
- Lip did not fully fold causing the platform to rest on safety legs (below-dock position).
- Lip did not fully fold and safety legs are retracted, causing the platform to rest on the safety stops (full below-dock position).

The hold-down ratchet assembly will keep the platform at the desired position until the platform release ring is pulled again.

OPERATION

Operating Instructions

DANGER

Stay clear of dock leveler when freight carrier is entering or leaving dock area.

DO NOT raise or lower the dock leveler if anyone is under or in front of leveler.

Keep hands and feet clear of pinch points. Avoid putting any part of your body near moving parts.

Failure to follow these instructions may result in severe personal injury or death.

WARNING

DO NOT activate the dock leveler until the truck/trailer is positioned squarely against the bumpers and the truck wheels are chocked.

Never remove the wheel chocks until loading and unloading is finished and truck driver has been given permission to leave.

DO NOT use the dock leveler if the freight carrier is too high or too low.

NEVER use a fork truck or any other material handling equipment to lower the dock leveler.

DO NOT drive any equipment onto the dock leveler until platform lip is resting on the truck/trailer with at least 4 in. (102 mm) of overlap.

Always maintain a safe distance from side edges of leveler during the loading and unloading process.

NEVER attempt to walk on an unsupported lip.

NEVER allow untrained personnel to operate the dock leveler.

NEVER attempt to lift any part of the leveler by hand.

Failure to follow these instructions may result in serious personal injury or death.

WARNING

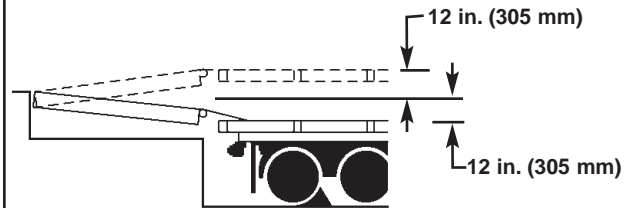

The CM-series mechanical dock leveler is designed to compensate for ± 12 in. (305 mm) of height difference between the loading dock and the truck bed. DO NOT use the dock leveler if the truck/trailer bed is more than 12 in. (305 mm) higher or lower than the dock floor.

DO NOT overload the dock leveler.

DO NOT operate any equipment while under the influence of alcohol or drugs.

DO NOT leave equipment or material unattended on the dock leveler.

Failure to follow these instructions may result in personal injury and/or damage to equipment.

IMPORTANT

When activating the leveler, always pull AND hold the platform release ring until the platform is at the full-raised position. Releasing the ring while the platform is still rising may result in damage to the equipment.

The dock leveler operation instructions are divided into the two methods of loading and unloading:

- For ramp loading and unloading, see Ramp Loading/Unloading Instructions on page 19.
- For end loading and unloading, see End Loading/Unloading Instructions on page 20.

Operating Instructions—Continued

Ramp Loading/Unloading Instructions

NOTE: If end unloading is required, see End Loading/Unloading Instructions on page 20.

1. Check to make sure truck/trailer is positioned squarely against dock bumpers.
2. Instruct driver to remain at the dock until the loading or unloading process has been completed.
3. Chock the truck/trailer wheels or use truck restraint if present.

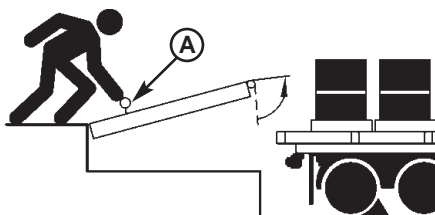

4. Raise the platform by pulling and holding the platform release ring (A).
5. Hold the release ring until the platform is at the fully-raised position and lip is fully extended.

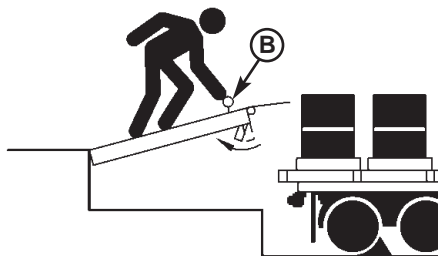

6. Walk out onto the platform. The platform will lower until the lip rests on the truck/trailer bed.

NOTE: If the truck/trailer bed is below dock level, pull and hold the safety leg retract pull ring (B) (located in a recess at front of the platform) until the platform lip is resting on the truck/trailer bed.

7. Make sure that the lip is fully extended and supported on the truck/trailer along the entire width of the platform with at least 4 in. (102 mm) of lip contacting the truck bed.

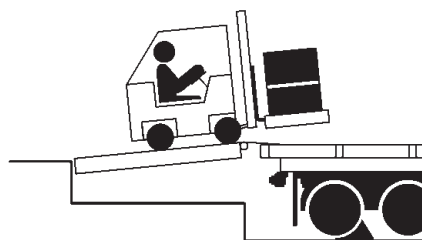

8. Proceed with loading or unloading.

NOTE: If end loading is necessary, see End Loading/Unloading Instructions on page 20.

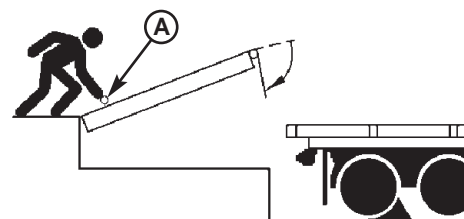

9. When the loading or unloading process has been completed, return platform to cross-traffic (stored) position as follows:
 - a. Raise the platform to the full-raised position by pulling and holding the platform release ring (A).
 - b. Lower platform by slowly walking out onto the platform allowing time for the lip to fully fold and clear the truck/trailer. Continue walking out on platform until platform lowers to the cross-traffic position (lip engages in the lip keepers).
10. Remove chocks from truck/trailer wheels or release truck restraint if used.
11. Indicate to driver that truck may leave the dock.

OPERATION

Operating Instructions—Continued

End Loading/Unloading Instructions

NOTE: End loading or unloading can be done with the dock at the cross-traffic position or below-dock position depending on the height of the truck/trailer bed.

1. Check to make sure truck/trailer is positioned squarely against dock bumpers.
2. Instruct driver to remain at the dock until the loading or unloading process has been completed.
3. Chock the truck/trailer wheels or use truck restraint if present.

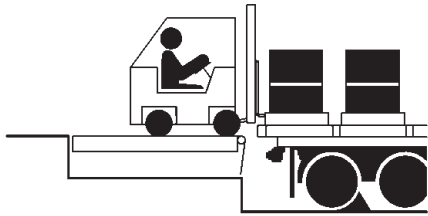

End Loading/Unloading—Platform at Cross-Traffic Position.

4. If truck/trailer bed is at or above dock floor level, leave leveler at the cross-traffic position and proceed with loading or unloading. When finished, perform steps 9 and 10.

If truck/trailer bed is below the dock floor level, perform steps 5–10.

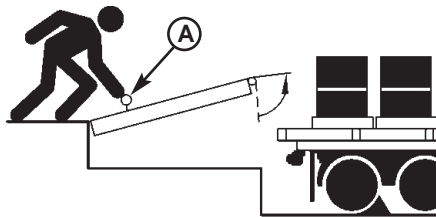

5. Pull and hold the platform release ring (A) until the platform is at the fully-raised position.

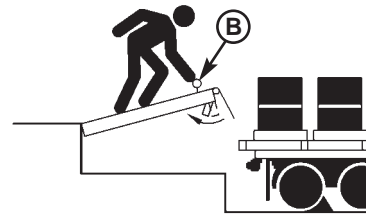

6. Slowly walk the platform down allowing enough time for the lip to fold. Just before the platform reaches the cross-traffic position, pull and hold the safety leg retract pull ring (B) (located in a recess at front of the platform). The platform will continue lowering to the full below dock position.

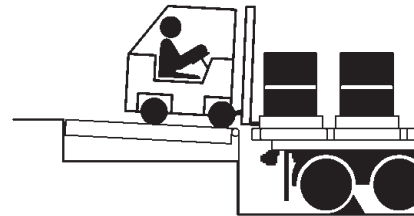

End Loading/Unloading—Platform at Below-Dock Position.

7. Proceed with loading or unloading.

NOTE: When end unloading is finished and additional access to the truck/trailer requires that the platform lip be extended, see Ramp Loading/Unloading Instructions on page 19 for further instructions.

8. When loading or unloading is finished, raise the platform to the full-raised position by pulling and holding the platform release ring. Slowly walk the platform down, allowing enough time for the lip to fold. The platform will lower to the cross-traffic position (lip engages in the lip keepers).
9. Remove chocks from truck/trailer wheels or release truck restraint if used.
10. Indicate to the driver that the truck may leave the dock.

Service Dock Leveler Safely

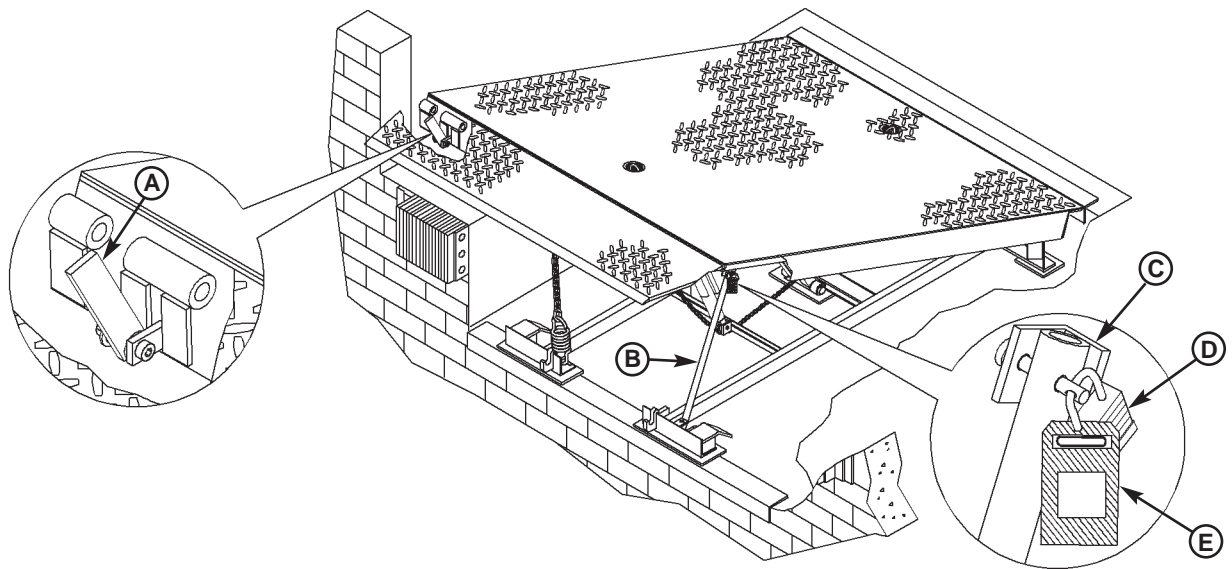

A—Lip Maintenance Prop B—Platform Maintenance Prop C—Angle Bracket D—Lockout Device E—Tagout Device

WARNING

Always post safety warnings and barricade the work area at dock level and ground level to prevent unauthorized use of the dock leveler before maintenance is complete. Failure to do this may result in serious personal injury or death.

WARNING

Always stand clear of the dock leveler lip when working in front of the dock leveler. Failure to do this may result in serious personal injury or death.

WARNING

The platform maintenance prop **MUST** be in the service position when working under the dock leveler. For maximum protection, use an OSHA approved locking device to lock the maintenance prop in the service position. Only the person servicing the equipment should have the key to unlock the maintenance prop.

Failure to follow these instructions may result in serious personal injury or death.

Whenever maintenance is to be performed under the dock leveler platform, support the platform with the platform maintenance prop (B).

Put the platform maintenance prop in the service (upright) position so that the prop is cradled in the angle bracket (C). Lock the platform maintenance prop in this position by inserting the locking pin and attaching an OSHA approved lockout device* (D) and tagout device* (E).

Only the person servicing the equipment should have the capability to remove the lockout device. The tagout device must inform that repairs are in process and clearly state who is responsible for the lockout condition.

If maintenance requires that the lip be in the extended position, raise the lip by hand and support the lip with the lip maintenance prop (A).

NOTE: Make sure to disengage the lip maintenance prop and allow the lip to fold fully before disengaging the platform maintenance prop.

* Refer to OSHA regulation 1910.147.

MAINTENANCE

Periodic Maintenance

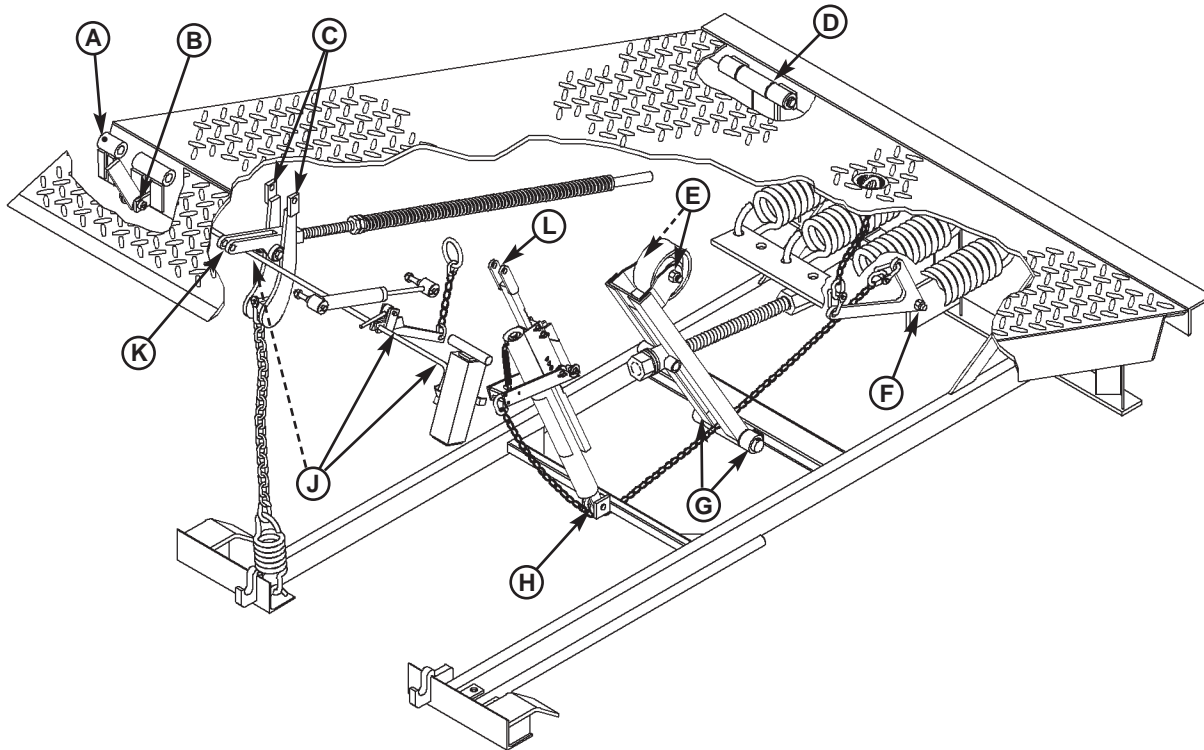

- | | | | |
|------------------------------|-------------------------------|-----------------------------|-----------------------------|
| A—Lip Hinge Grease Fittings | D—Platform Hinge Area | G—Lift Arm Pivot | K—Lip Lift Assist Pin |
| B—Lip Maintenance Prop Pivot | E—Lift Arm Roller Bushing | H—Hold-Down Pivot/Pulley | L—Hold Down-to-Platform Pin |
| C—Lip Link Pivots | F—E-Z Release Bellcrank Pivot | J—Safety Leg Linkage Pivots | |

WARNING

Always post safety warnings and barricade the work area at dock level and ground level to prevent unauthorized use of the dock leveler before maintenance is complete. Failure to do this may result in serious personal injury or death.

WARNING

Always stand clear of the dock leveler lip when working in front of the dock leveler. Failure to do this may result in serious personal injury or death.

WARNING

The platform maintenance prop **MUST** be in the service position when working under the dock leveler. For maximum protection, use an OSHA approved locking device to lock the maintenance prop in the service position. Only the person servicing the equipment should have the key to unlock the maintenance prop.

Failure to follow these instructions may result in serious personal injury or death.

Regular maintenance must be performed on a weekly and quarterly schedule.

Weekly Maintenance

- Operate the dock leveler through the complete operating cycle to maintain lubrication.

NOTE: To thoroughly inspect the platform hinge area, position the platform in the full below-dock position.

- Inspect the platform hinge and the lip hinge areas. The hinge areas must be kept free of dirt and debris. Build-up of foreign material in the hinge areas will increase wear and cause abnormal operation.

IMPORTANT

Failure to properly lubricate the dock leveler will cause abnormal operation of the leveler.

DO NOT lubricate the hold-down ratchet bar and pawl.

Quarterly Maintenance

- Lubricate the following areas with light-weight machine oil:

(B)—Lip maintenance prop pivot

(C)—Lip link pivots

(F)—E-Z release bellcrank pivot

(H)—Hold-down pivot/pulley

(J)—Safety leg linkage pivots

(L)—Hold down-to-platform pin

- Lubricate the following areas with white lithium grease:

(A)—Lip hinge area (inject grease into all the lip hinge grease fittings)

(D)—Platform hinge area (inject grease into all the platform hinge grease fittings)

(E)—Lift arm roller bushing

(G)—Lift arm pivot

(K)—Lip assist pin

ADJUSTMENTS

Adjust Lift Arm Spring and Lip Assist Spring Tension

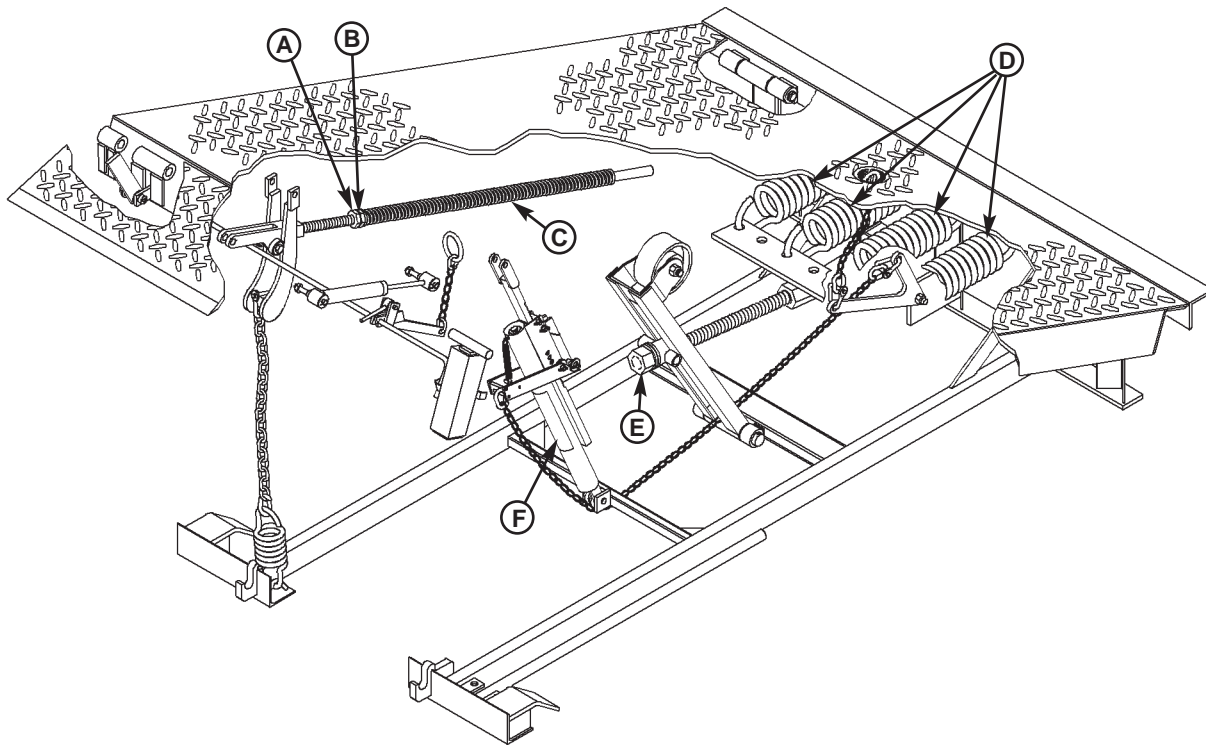

A—Jam Nut
B—Nut

C—Lip Assist Spring
D—Lift Springs

E—Lift Spring Bolt
F—Hold-Down Mechanism

WARNING

Always post safety warnings and barricade the work area at dock level and ground level to prevent unauthorized use of the dock leveler before maintenance is complete. Failure to do this may result in serious personal injury or death.

WARNING

Always stand clear of the dock leveler lip when working in front of the dock leveler. Failure to do this may result in serious personal injury or death.

WARNING

The platform maintenance prop **MUST** be in the service position when working under the dock leveler. For maximum protection, use an OSHA approved locking device to lock the maintenance prop in the service position. Only the person servicing the equipment should have the key to unlock the maintenance prop.

Failure to follow these instructions may result in serious personal injury or death.

NOTE: Adjusting the tension of lift springs (D) usually requires that the lip assist spring (C) also be adjusted.

If the platform does not rise fully and/or lip does not extend fully, the lift spring tension may be set too low.

If the platform cannot be walked down or is difficult to walk down, the lift spring tension may be set too high.



WARNING

If the platform does not rise fully on its own, it may be necessary to use an external lifting device. Use a lifting device with the appropriate lifting capacity to safely raise the platform. Make sure to engage and lock the platform maintenance prop after raising the platform. Failure to do this may result in serious personal injury or death.

IMPORTANT

When using an external lifting device to raise the platform, make sure hold-down mechanism (F) is disengaged. Pull and hold platform release ring during the lifting process to avoid shearing the ratchet pawl and ratchet bar teeth.

1. Raise the platform and engage the platform maintenance prop. Lock the maintenance prop in the service position using an appropriate locking device.

2. Adjust tension of lift springs (D) as follows:

NOTE: Use 1/2 turn increments when adjusting lift spring bolt (E). Check platform operation after each adjustment. Repeat until proper operation is obtained.

- To increase lift spring tension, turn lift spring bolt (E) clockwise.
- To decrease lift spring tension, turn lift spring bolt (E) counterclockwise.

3. After lift spring adjustment is completed, check operation of the lip.

- If the lip folds before the platform can be walked down, tension of lip assist spring (C) may be set too low.
- If the lip does not fold fully or takes too long to fold, tension of lip assist spring (C) may be set too high.

4. Adjust lip assist spring tension as follows:

NOTE: Use two-turn increments when adjusting lip assist spring (C). Check lip operation after each adjustment. Repeat until proper operation is obtained.

- a. Loosen jam nut (A).
- b. To increase spring tension, turn nut (B) clockwise.
- c. To decrease spring tension, turn nut (B) counterclockwise.
- d. Tighten jam nut.

5. Recheck operation of platform and lip. Readjust lift spring tension and lip assist spring tension until proper operation is obtained.

ADJUSTMENTS

Adjust Lip Stop Bolt

WARNING

Always post safety warnings and barricade the work area at dock level and ground level to prevent unauthorized use of the dock leveler before maintenance is complete. Failure to do this may result in serious personal injury or death.

WARNING

Always stand clear of the dock leveler lip when working in front of the dock leveler. Failure to do this may result in serious personal injury or death.

WARNING

The platform maintenance prop **MUST** be in the service position when working under the dock leveler. For maximum protection, use an OSHA approved locking device to lock the maintenance prop in the service position. Only the person servicing the equipment should have the key to unlock the maintenance prop.

Failure to follow these instructions may result in serious personal injury or death.

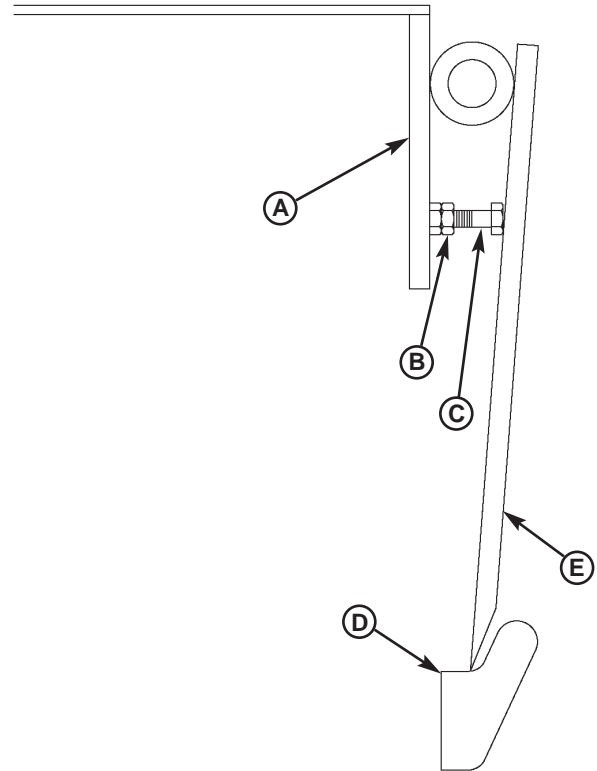

A—Platform Frame
B—Jam Nut
C—Stop Bolt

D—Lip Keeper
E—Lip

Check that lip (E) is fully resting on the lip keepers (D) and at the lowest part of the keeper cradle. If lip is not resting properly in keepers, perform the following adjustment.

1. Fully raise platform. Manually raise the lip and engage lip maintenance prop.
2. Loosen jam nut (B).
3. Adjust stop bolt (C) as necessary.
 - Turn stop bolt “in” (clockwise) to allow lip to fold closer to platform frame (A).
 - Turn stop bolt “out” (counterclockwise) to hold lip further away from platform frame (A).
4. Tighten jam nut.
5. Disengage lip maintenance prop.
6. Walk platform down to cross-traffic (stored) position.
7. Check lip position in both keepers. Repeat procedure if necessary.

Troubleshooting



WARNING

Always post safety warnings and barricade the work area at dock level and ground level to prevent unauthorized use of the dock leveler before maintenance is complete. Failure to do this may result in serious personal injury or death.



WARNING

Always stand clear of the dock leveler lip when working in front of the dock leveler. Failure to do this may result in serious personal injury or death.



WARNING

The platform maintenance prop **MUST** be in the service position when working under the dock leveler. For maximum protection, use an OSHA approved locking device to lock the maintenance prop in the service position. Only the person servicing the equipment should have the key to unlock the maintenance prop.

Failure to follow these instructions may result in serious personal injury or death.

Symptom	Possible Cause	Solution
Platform does not rise.	Heavy object(s) on platform.	Remove object(s) from platform. <i>NOTE: For safety reasons, the dock leveler is designed to lift only the platform's own weight.</i>
	Disconnected or broken release cable.	Connect or replace cable.
	Dock leveler binds.	Check for visible obstructions that could cause binding. Check weather seal if equipped. If no obstructions found, call Poweramp Technical Services. See inside back cover for phone number and address.
Platform rises slowly or does not rise to the full raised position.	Heavy object(s) on platform.	Remove object(s) from platform. <i>NOTE: For safety reasons, the dock leveler is designed to lift only the platform's own weight.</i>
	Dock leveler binds.	Check for visible obstructions that could cause binding. Check weather seal if equipped. If no obstructions found, call Poweramp Technical Services. See inside back cover for phone number and address.
	Insufficient main spring tension.	Increase tension on main springs. (See Adjust Lift Arm Spring and Lip Assist Spring Tension in the Adjustments section.)
	Damaged or worn hold-down mechanism.	Clean and inspect hold-down mechanism.

TROUBLESHOOTING

Symptom	Possible Cause	Solution
Platform rises to full height, but lip does not fully extend.	Lip assist chain disconnected or broken.	Connect or replace chain.
	Insufficient main spring tension.	Increase tension on main lift springs. (See Adjust Lift Arm Spring and Lip Assist Spring Tension in the Adjustments section.)
	Insufficient lip assist force.	Increase lip assist spring tension. (See Adjust Lift Arm Spring and Lip Assist Spring Tension in the Adjustments section.)
Platform does not lower when operator walks out onto the platform.	Excessive main spring tension.	Reduce main spring tension. (See Adjust Lift Arm Spring and Lip Assist Spring Tension in the Adjustments section.)
	Damaged or worn hold-down mechanism.	Clean and inspect hold-down mechanism.
Lip folds too fast during normal walk-down.	Insufficient lip assist force.	Increase lip assist spring tension. (See Adjust Lift Arm Spring and Lip Assist Spring Tension in the Adjustments section.)
	Disconnected, worn, or broken shock absorber.	Inspect shock absorber. Connect or replace shock absorber.
Platform does not stay down.	Entangled release chain.	Remove cause of entanglement.
	Dirt impacted in ratchet bar teeth.	Clean and inspect ratchet bar and ratchet pawl teeth. DO NOT lubricate the ratchet assembly.
	Broken or damaged ratchet assembly teeth.	Replace ratchet assembly. DO NOT lubricate the ratchet assembly.
	Disconnected or broken hold-down pivot pins.	Replace hold-down pivot pins.
	Damaged or worn hold-down mechanism.	Clean and inspect hold-down mechanism.
Lip does not fold after truck departs.	Lip hinge binding because of lack of lubrication	Inject grease into all of the lip hinge grease fittings. (See Periodic Maintenance in the Maintenance section.)
	Excessive lip assist force.	Decrease lip assist spring tension. (See Adjust Lift Arm Spring and Lip Assist Spring Tension in the Adjustments section.)

Hold-Down Mechanism

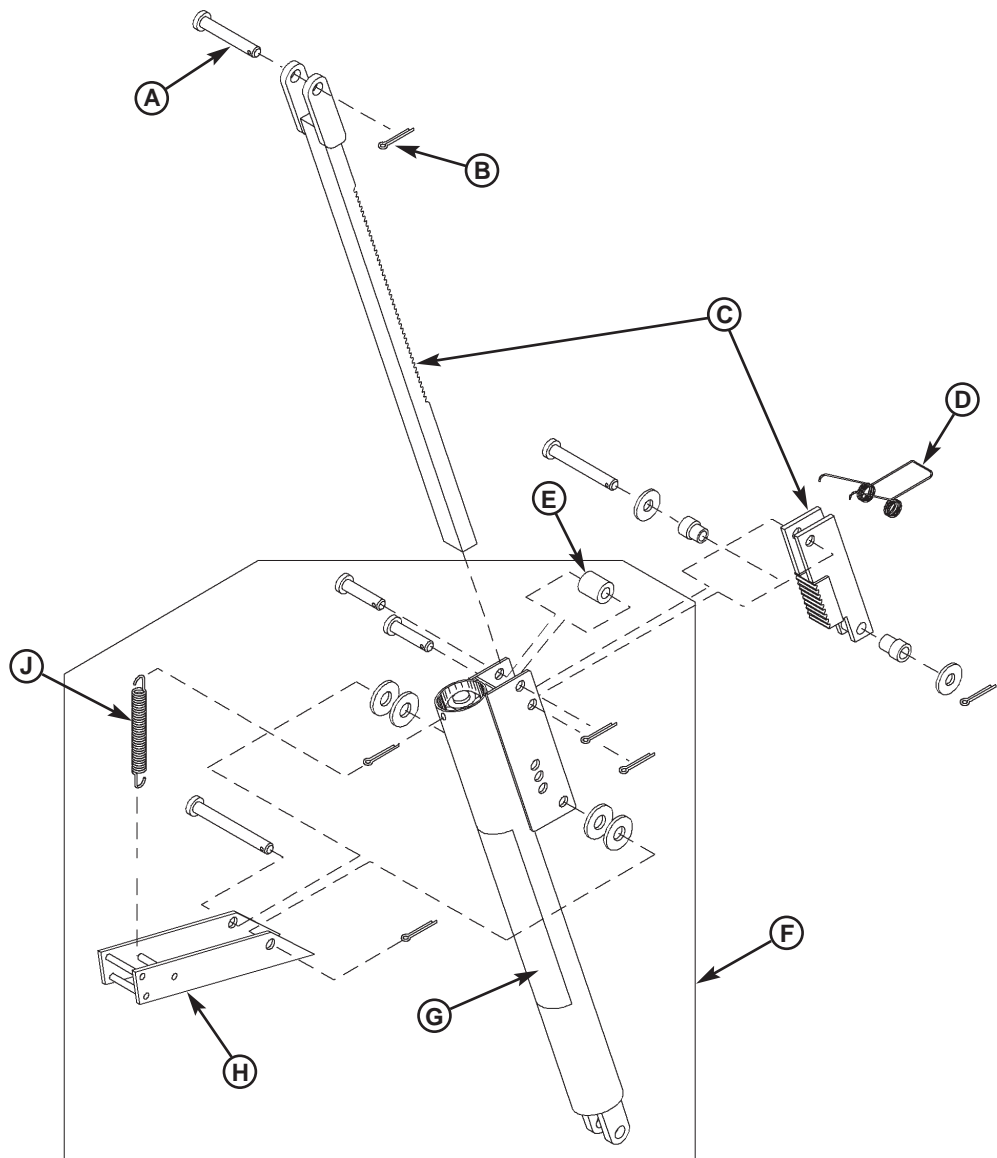

Item	Quantity	Part Number	Description
A	1	OTH-2355	Pin, Clevis
B	1	OTH-2374	Pin, Cotter
C	1	OTH-2575	Ratchet Bar and Pawl Assembly Set
D	1	OTH-2556	Spring, Pawl
E	1	OTH-2568	Bearing, Ratchet Bar
F	1	OTH-2565	Hold-Down Float Assembly
G	1	OTH-1763	Decal, Warning
H	1	OTH-2569	Arm, Release
J	1	OTH-2559	Spring, Release Arm

Frame Components

Item	Quantity	Part Number	Description
A	1	OTH-____ ¹	Frame, Welded Assembly
		OTH-____ ¹	Frame, Clean Sweep, Welded Assembly (Optional)
B	1	OTH-2555	Spring, Lip Link
C	1	OTH-2416	Lap Link, 3/16 x 1.0 in.
D	1	OTH-6832	Chain, Lip Assist Link
E	3	OTH-2421	Cold Shut Link, 5/16 in.
F	1	OTH-____ ¹	Bolt, Spring Adjuster
	1	OTH-____ ¹	Plate, Spring Tensioner.
	2	OTH-2218	Washer
G	1	OPT-6417 ¹	Lift Arm, Short, 25"
	1	OPT-6418 ¹	Lift Arm, Long, 27"
J	1	OPH-2402	Roller Assembly, Cam
K	AR*	OTH-____ ¹	Spring, Lift
L	3	OTH-2377	Pin, Cotter, 1/4 x 2 in.
M	3	OTH-2370	Pin, Rear Hinge
	3	OTP-6441	Pin Assembly, Rear Hinge (Includes Items L and M)
N	1	OTH-2060	Bolt, Shoulder
P	2	OTH-2433	Cold Shut Link
Q	1	OTH-2423	Ring, Chain
R	3	OTH-2425	Quick Link
S	1	OTH-2131	Nut, Nylon Lock
T	1	OTP-6919	Chain, Release Pull, 9-1/2 in. (241 mm) length
U	1	OTP-6928	Arm, E-Z Release
V	1	OTP-6921 ¹	Chain, Hold-Down Release 5 ft (1524 mm) length
	1	OTP-6915 ¹	Chain, Hold-Down Release 6 ft (1829 mm) length
	1	OTP-6918 ¹	Chain, Hold-Down Release 8 ft (2438 mm) length
	1	OTP-6916 ¹	Chain, Hold-Down Release 10 ft (3048 mm) length
W	1	OTP-____ ¹	Prop, Maintenance
X	2	OTP-____ ¹	Keeper, Lip
Y	1	OTH-2356	Pin, Clevis
Z	1	OTH-2405	Roller, Hold-Down Release Chain
AA	1	OTH-2374	Pin, Cotter
AB	1	OTH-2563	Hold-Down Assembly
AC	1	OTH-2392	Pin, Roll
AD	1	OTH-2222	Washer
AE	1	OTH-6885	Pin
	1	OTH-6443	Lift Arm Pivot Assembly (Includes Items AD, AE, & AF)
	1	OTP-6920	Chain Assembly, Release Pull (Includes Items P, Q, R, and T)
	1	OTP-6921	Chain Assembly, Hold-Down Release, 5 ft (1.5 m) (Includes Items P, R, and V)
	1	OTP-6922	Chain Assembly, Hold-Down Release, 6 ft (1.8 m) (Includes Items P, R, and V)
	1	OTP-6923	Chain Assembly, Hold-Down Release, 8 ft (2.4 m) (Includes Items P, R, and V)
	1	OTP-6924	Chain Assembly, Hold-Down Release, 10 ft (3.0 m) (Includes Items P, R, and V)

*AR = As Required

¹Provide dock leveler serial number, platform size, lip size and pit depth when calling or faxing orders.

PARTS

Platform Components

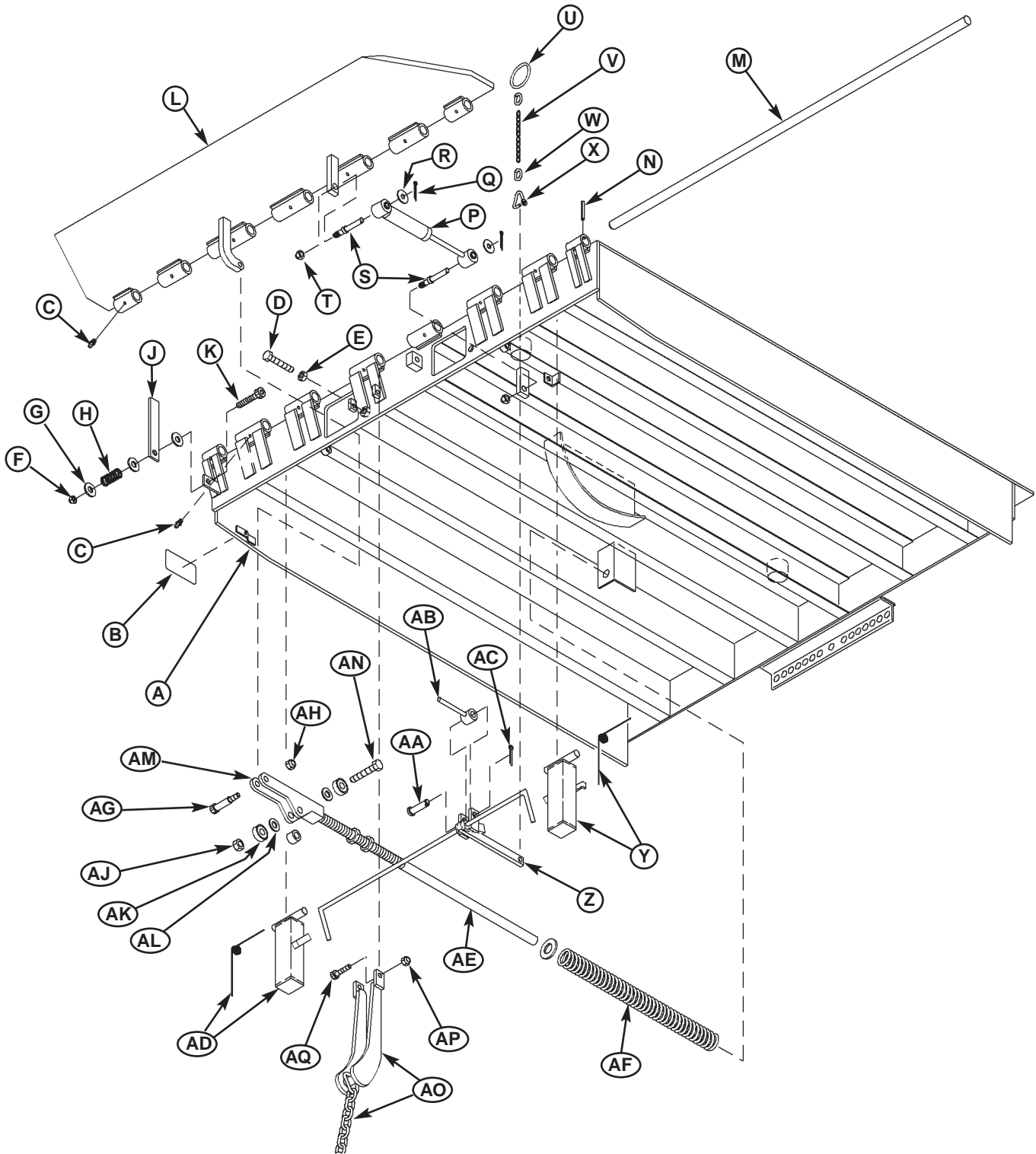

Platform Components

Item	Quantity	Part Number	Description
A	1	OTH-____ ¹	Platform, Welded Assembly
B	1	OTH-1721	Decal, Warning
C	AR*	OTH-2424	Fitting, Grease
D	1	OTH-2075	Cap Screw, Lip Stop
E	1	OTH-2160	Nut, Jam
F	1	OTH-2131	Nut, Nylon Lock
G	1	OTH-	Washer
H	1	OTH-	Spring, Lip Maintenance Prop
J	1	OTH-	Prop, Lip Maintenance (Optional)
K	1	OTH-	Cap Screw
L	1	OTH-____ ¹	Lip, Welded Assembly
M	1	OTH-____ ¹	Pin, Lip Hinge
N	2	OTH-	Pin, Roll
Shock Absorber Assembly			
P	1	OTH-2582	Shock Absorber
Q	2	OTH-2374	Pin, Cotter
R	2	OTH-2210	Washer
S	2	OTH-2351	Bolt, Clevis
T	2	OTH-2163	Nut, Nylon Lock
	1	OTH-6465	Single Shock Absorber Assembly (Includes Items P–T)
Safety Legs Assembly			
U	1	OTH-2423	Ring, Chain
V	2	OTH-2425	Quick Link
W	1	OTH-6895	Chain, Safety Leg
X	1	OTH-2433	Cold Shut Link
Y	1	OTH-6231	Leg, Left Safety Assembly with Spring
	1	OTH-6229	Leg, Left Safety, Tall [10 ft (3048 mm) Platform]
Z	1	OTP-6235	Pull Bar Rod Assembly, Safety Leg
AA	1	OTH-2352	Pin, Clevis
AB	1	OTP-6646	Rod, Push
AC	1	OTH-2374	Pin, Cotter
AD	1	OTH-6232	Leg, Right Safety Assembly with Spring
	1	OTH-6230	Leg, Right Safety, Tall [10 ft (3048 mm) Platform]
	1	OTH-6233	Chain Assembly, Safety Leg (Includes Items Y, Z, AA, and AB)

*AR = As Required

¹ Provide dock leveler serial number, platform size, and lip size when calling or faxing orders.

Continued on next page

PARTS

Platform Components

Continued from previous page

Item	Quantity	Part Number	Description
Lip Assist Assembly			
AE*	1	OTP-6835	Rod, Lip Assist Adjuster, (1-1/8 in. x 34 in., Heavy Duty Short)
		OTP-6407	Rod, Lip Assist Adjuster, (1-1/8 in. x 44 in., Heavy Duty Long)
AF	1	OTH-2550	Spring, STD, Lip Assist (For OTP-6835 Rod)
		OTH-2553	Spring, HD, Lip Assist (For OTP-6836 Rod)
AG	1	OTH-2061	Bolt, Shoulder
AH	1	OTH-2131	Nut, Nylon Lock
AJ	1	OTH-2076	Nut, Nylon Lock, 5/8 -11 UNC
AK	2	OTH-2404	Bearing, Roller
AL	2	OTH-2211	Washer, 5/8", 1-5/16 in. OD x 11/16 in. ID
AM	1	OTH-6834	Spacer, 1-1/4 in. OD x 3/4 in. ID x 1 in.
AN	1	OTH-2076	Cap Screw, 5/8 -11 UNC x 3-1/2 in.
AO	1	OTH-6408	Link, Lip With Chain
AP	2	OTH-2131	Nut, Nylon Lock, 3/8 -16 in.
AQ	2	OTH-2060	Bolt, Socket-Head Shoulder, 3/8 -16 x 1-3/4 in.

*AE includes (2)AP,(2)AQ, (1)AS, and (1)AN

Toe Guard/Weather Seal—Optional

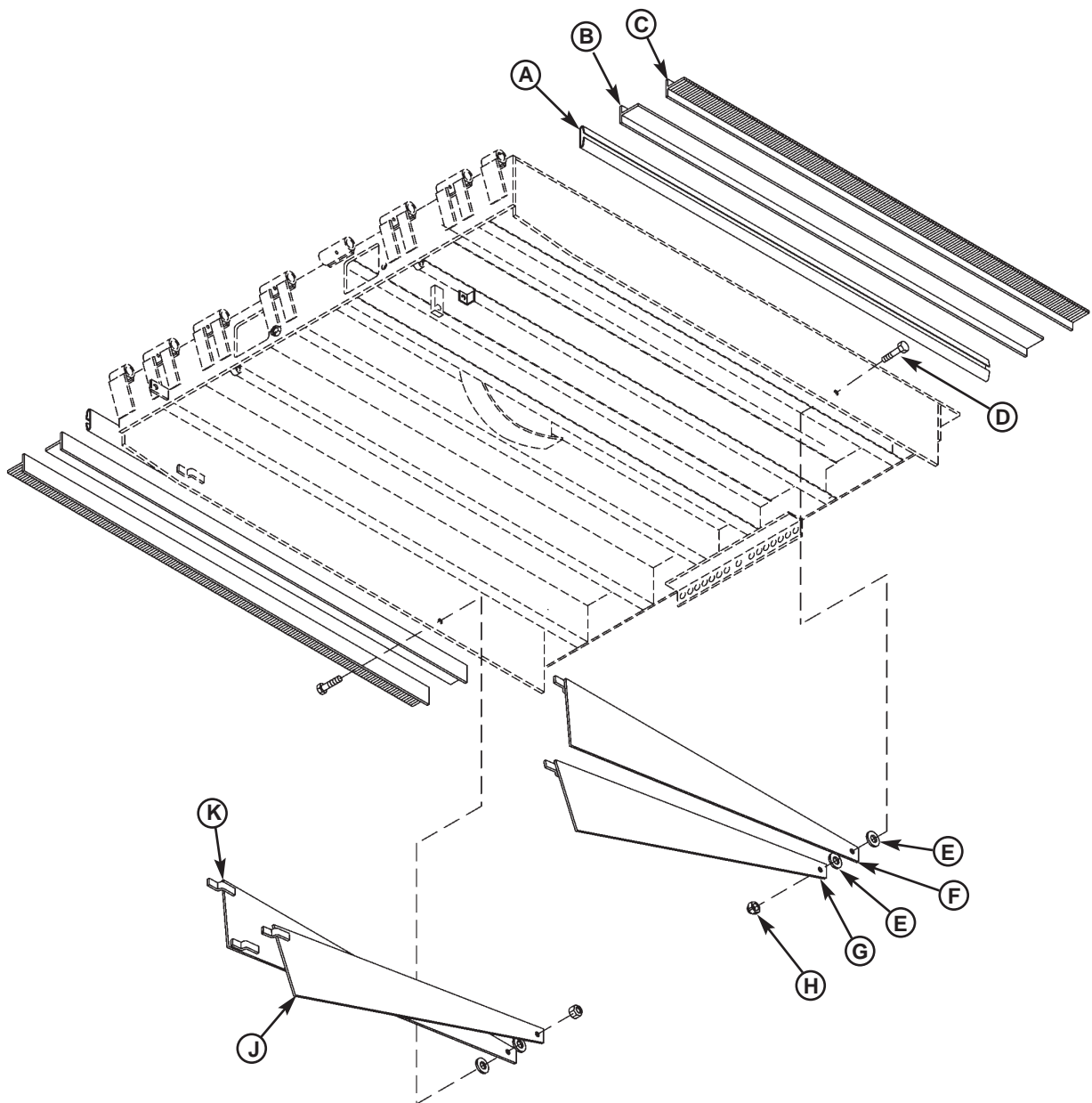

Item	Quantity	Part Number	Description
A	2	OTH-2818	Channel, Weather Seal
B	2	OTH-2824	T-Rubber, Weather Seal
C	2	OTH-2822	Brush, Weather Seal
	2	OTH-2820	Extrusion, Brush Weather Seal
D	2	OTH-2041	Cap Screw
E	4	OTH-2207	Washer
F	1	2101-	Toe Guard, Left Top Panel
G	1	2101-	Toe Guard, Left Lower Panel
H	2	OTH-2131	Nut, Nylon Lock
J	2	R913-____	Toe Guard, Right Lower Panel
K	2	R916-____	Toe Guard, Right Top Panel

This page intentionally left blank

Customer Information

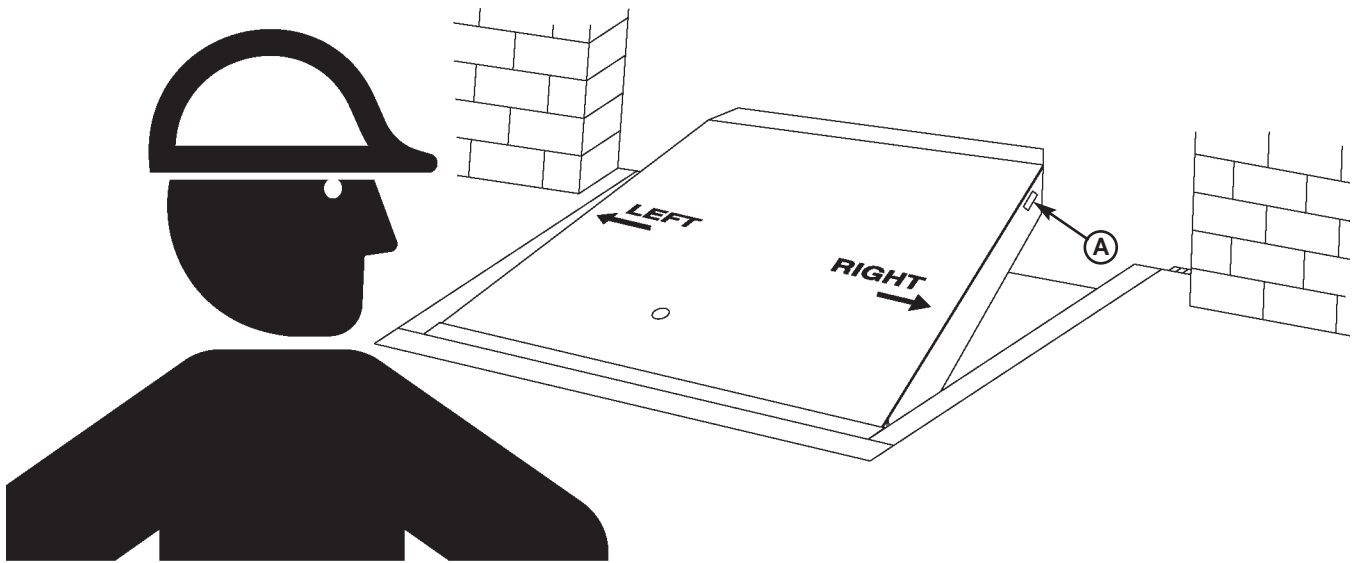

NOTE: Refer to illustration for left/right orientation of dock leveler.

The model/serial number decal (A) is located on the right platform joist near the front (lip) of dock leveler.

When you receive your CM-series dock leveler, write down the dock leveler model and serial number in the form provided. This will help ensure safe keeping of the numbers in the event the model/serial number decal (A) becomes lost or damaged.

Also, write down Systems, Inc.'s job number, the company that installed the dock leveler, and the original owner's name. This will all help to identify the specific dock leveler if more information is required.

When ordering, use part numbers and description to help identify the item ordered. Do not use "item" numbers. These are only for locating the position of the parts. Always give dock leveler MODEL NUMBER and/or SERIAL NUMBER.

For service, call or contact:

Systems, Inc.
P.O. Box 309
Germantown, WI 53022

Phone: (800) 643-5424
Fax: (262) 257-7349

<u>Dock Leveler Information</u>	
Model	_____
Serial No.	_____
Systems, Inc., Job No.	_____
<u>Original Owner Information</u>	
Name	_____
Address	_____ _____
<u>Installer Information</u>	
Name	_____
Address	_____ _____
Date of Installation	_____

POWERAMP WARRANTY

CM-SERIES MECHANICAL LEVELER

Systems, Inc., guarantees the materials, components, and workmanship in your Poweramp CM-Series dock leveler to be of the highest quality and to be free of defects in material and workmanship for a full One (1) Year Base Warranty on all components. The Base Warranty includes replacement parts, labor, and freight.

Structural components carry a Ten (10) Year Pro-Rated Parts Warranty. Example: after two years customer is responsible for 20%, three years 30%, etc.

Specifically, the structural warranty includes the frame, deck section, lip section, rear hinge, and front hinge.

Systems, Inc., warrants all components to be free of defects in material and workmanship, under normal use, during the warranty period. This base warranty period begins upon the completion of the installation or the Sixtieth (60th) day after shipment, whichever is earlier.

All guarantee claims will be settled on a timely basis when defects are found to be from other than improper installation, operating contrary to instructions or beyond rated load capacities, abuse, careless or negligent use, or failure to maintain the unit as recommended by the owner's manual.

There are no guarantees, either expressed or implied, including any implied guarantees of merchantability or fitness for a particular purpose which shall extend beyond the guarantee periods indicated above. This guarantee is valid only if the unit(s) is unaltered from original condition as delivered from the factory and a survey is completed by a Poweramp representative.